



Priport Controller UC5E

Service Manual
(Revision 1-3)

Table of Contents

SAFETY INFORMATION	3
GENERAL REMARKS	4
1. OVERALL INFORMATION.....	5
1.1 HOST SYSTEMS	5
1.2 BASIC SPECIFICATION	5
1.3 FONT INFORMATION	5
1.4 VIDEO INTERFACE KITS	6
2. BASIC FUNCTION	7
2.1 BASIC CONFIGURATION	7
2.2 SPECIFICATIONS AND CONFIGURATIONS OF I/O PORTS	8
3. VIDEO I/F INSTALLATION PROCEDURES	9
3.1 VIDEO I/F KIT TYPE-10 PARTS LIST	10
3.2 INSTALLATION PROCEDURES FOR INTERFACE KITS	10
4. OPERATION VERIFICATION.....	10
4.1 TOOLS.....	10
4.2 TESTS	10
5. TROUBLESHOOTING	12
5.1 BASIC STEPS FOR TROUBLESHOOTING	12
5.2 TROUBLESHOOTING FLOW.....	14
5.3 PRI PORT/UC5E FAILURE IDENTIFICATION.....	15
5.4 SUBASSEMBLY TROUBLESHOOTING	16
5.5 MEMORY TROUBLESHOOTING	17
5.6 LED STATUS LIGHT SEQUENCE AND CONDITIONS.....	17
5.7 DIAGNOSTIC TEST PAGE CONTENTS	19
5.8 CHECKING PRINTER DRIVER OPERATION	20
5.9 COLLECTING INFORMATION FOR A PROBLEM REPORT	21
6. DISASSEMBLY / ASSEMBLY	22
6.1 REQUIRED TOOLS AND PRECAUTIONS	22
6.2 ZIP RIP FOR MODEL C237	23
6.3 ZIP RIP FOR MODEL C235.....	29
6.4 UPGRADING UC5E FIRMWARE	34
6.5 MEMORY REPLACEMENT	35
7. PARTS LIST	36
7.1 UC5E FOR MODEL C235 (DIAGRAM)	36
7.2 UC5E FOR MODEL C237 (DIAGRAM)	37
PARTS LIST C235 AND C237	38
7.3 PC CONTROLLER I/F KIT TYPE-10	39

IMPORTANT SAFETY NOTICES

PREVENTION OF PHYSICAL INJURY

1. Before disassembling or assembling parts of the printer and peripherals, make sure that the power cord is unplugged.
2. The wall outlet should be near the UC5E and easily accessible.
3. If any adjustment or operation check has to be made with exterior covers off or open while the main switch is turned on, keep hands away from electrified or mechanically driven components.

OBSERVANCE OF ELECTRICAL SAFETY STANDARDS

The UC5E must be installed and maintained by a customer service representative who has completed the training course on those models.

SAFETY AND ECOLOGICAL NOTES FOR DISPOSAL

Dispose of replaced parts in accordance with local regulations.

Safety Information

This equipment must be connected to SELV circuits of other equipment complying with the requirements of SELV circuits as defined in the standards EN60950, IEC950 and CSAC22.2 NO. 950, UL 1950.

Renseignements de sécurité

IL est absolument nécessaire d'interconnecter cet équipement dux circuits SELV de tout équipement qui se conforme dux besoins des circuits SELV comme précisés dux standards EN60950, IEC950 et CSAC22.2 NO. 950, UL 1950

Sicherheit-Auskünfte

Diese Ausrüstung muß zur SELV Schaltungen von anderen Ausrüstungen, die mit den Forderungen von SELV Schaltungen die in den Standards EN60950, IEC950 und CSAC22.2 NO 950, UL1950 definiert werden, nach kommen.

General Remarks

The following table shows the conversion of the model names for each manufacturer:

<i>Model Code</i>	<i>Company</i>	<i>Model Name</i>
C237	Ricoh	JP1210/1230/1250
	Gestetner	5308/5308L/5308B
	RexRotary	1225/1225L/1225B
	Nashuatec	CP308/CP308L/CP308B
	Savin	3150eDNP
	Standard	SD330
C235	Ricoh	JP8000
	Gestetner	5490
	RexRotary	1395
	Nashuatec	CP490
	Savin	3450DNP
	Standard	SD630

1. OVERALL INFORMATION

1.1 HOST SYSTEMS

UC5E is an embedded GDI raster image processor for PRIPORTs. The following are the target computer hosts for this UC5E.

Target Host Computer Systems

- IBM PC/AT compatible PC with Windows 3.11 for workgroups, ME, 2000, 95 with Internet Explorer 4.01 SP1, Windows 98, or Windows NT4.0 with SP3 operating systems.

There are no minimum system hardware requirements, other than those imposed by the operating systems.

1.2 BASIC SPECIFICATION

Contents	Description
Configuration	Internal embedded controller
Priport Models	C235 and C237
I/O Interfaces	Host: • Parallel I/F (ECP/EPP Bi-directional) Video: RSVI Interface
Fonts	True Type
Image Resolution RAM	300 dpi, 600 dpi Standard: 16MB, (72-pin 60ns EDO SIMM, non-parity, at 5 volts with 2K maximum refresh rate)
Paper Size	A3, A4, B4, B5, A5, Custom size (Operating System Depending), US Letter, US Legal, US Tabloid

Table 1.2. Basic UC5E Specifications.

1.3 FONTS

All fonts reside with in the host computer. Systems fonts are all True Type Fonts.

1.4 VIDEO INTERFACE KITS

Description	Contents
PC Controller I/F Kit Type-10	For the connection to Model C235 and Model C237

Table 1.4. Interface Kits for use with the UC5E.

2. BASIC FUNCTION

2.1 BASIC CONFIGURATION

2.1.1. MAIN BOARD SPECIFICATIONS

Main Printed Circuit Board specifications are listed in the table below.

Description	UC5E Controller
CPU	A.D.S.P. CHIP
RAM	16MB (SIMM)
Flash ROM	1Mb Programmable Eprom

Table 2.1. Main Board Specifications.

2.1.2. MAIN BOARD LAYOUT

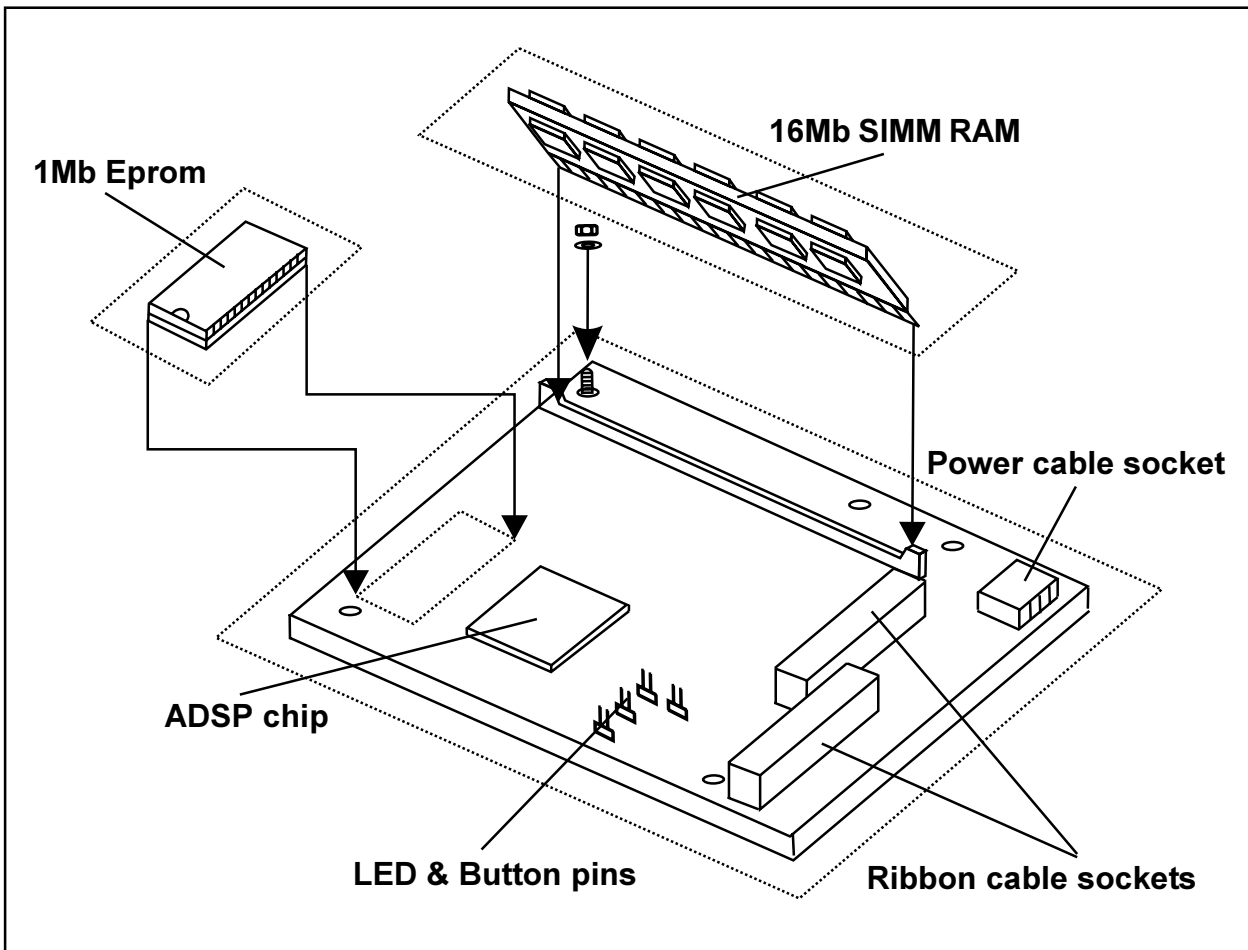

Figure 2.1.2. Main Board Layout

2.2 SPECIFICATIONS AND CONFIGURATIONS OF I/O PORT

The ZipRip UC5E Controller supports connection to a computer for printing from the following port: • Parallel Port (IEEE 1284, ECP/EPP Bi-directional)

2.2.1 PARALLEL MINI CENTRONICS INPUT PORT

2.2.1.1 DESCRIPTION

The high-performance parallel input/output port on the UC5E utilizes the IEEE 1284 – 1994 design, for high-speed communication between the computer and UC5E. Be sure to use a cable conforming to this design standard to realize the full data speed benefit from this interface.

2.2.1.2 IEEE 1284 PARALLEL PORT CHARACTERISTICS

Maximum data speed: 2 MBytes/sec.

Maximum cable length: 1 metre (3.5 feet).

Chassis connector type: IEEE 1284 Type B (Centronics).

Design standard: IEEE 1284 – 1994 .

To use this interface at the highest data rate, the parallel port (e.g., LPT1:) on the user's computer must be configured as an ECP or ECP/EPP (not EPP) Printer Port.

2.2.1.3 IEEE 1284 PARALLEL PORT PIN OUT

IEEE 1284 Type B Centronics

<= in => out	DB25pin	Cent Signal	Name of Bit	Reg Function Notes
=>	1	1	-Strobe C0-	Set Low pulse >0.5 us to send
=>	2	2	Data 0 D0	Set to least significant data
=>	3	3	Data 1 D1	
=>	4	4	Data 2 D2	
=>	5	5	Data 3 D3	
=>	6	6	Data 4 D4	
=>	7	7	Data 5 D5	
=>	8	8	Data 6 D6	
=>	9	9	Data 7 D7	Set to most significant data
<=	10	10	-Ack S6+	IRQ Low Pulse ~ 5 uS, after accept
<=	11	11	+Busy S7-	High for Busy/Offline/Error
<=	12	12	+PaperEnd S5+	High for out of paper
<=	13	13	+SelectIn S4+	High for printer selected
=>	14	14	-AutoFd C1-	Set Low to autofeed one line
<=	15	32	-Error S3+	Low for Error/Offline/ PaperEnd
=>	16	31	-Init C2+	Set Low pulse > 50uS to init
=>	17	36	-Select C3-	Set Low to select printer
==	18-25	19-30	Ground	
	33,17,		Ground	
	16		Ground	

3. VIDEO I/F INSTALLATION PROCEDURES

3.1 VIDEO I/F KIT TYPE-10 PARTS LIST

No.	Description	Qty.
32	Interface Board	1
33	Relay Harness	1
34	Stepped Screw – M2.6	2
35	Tapping Screw – M3 x 6	2

Table 3.2.1. Video I/F kit Type-10.

3.2 INSTALLATION PROCEDURES FOR INTERFACE KITS

- NOTE:**
- 1) The UC5E Controller is designed for the Model C237 and Model C235 range of Digital Duplicators.
 - 2) Numbers in parentheses () in the installation procedures correspond to the part numbers in Tables 3.1.

3.2.1 MODEL C237

1. Turn off the main switch and unplug the power cord.

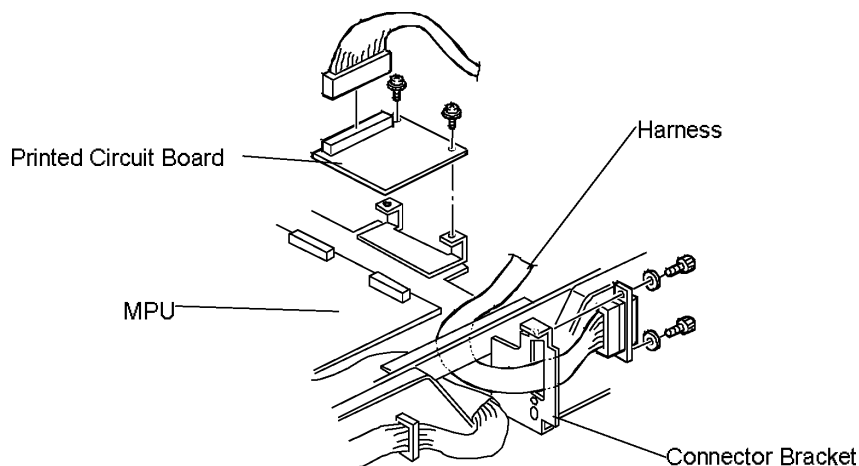

2. Remove the upper rear cover.
3. Remove the MPU cover.
4. Connect CN102 of the printed circuit board (32) to CN110 of the MPU board and secure it using two screws (35).
5. Connect the harness (33) to CN101 of the printed circuit Board, and secure it to the connector bracket using two stepped screws (34).
6. Remove the communications port cover plate (blinding cover) from the upper rear cover.
7. Reinstall the MPU cover.
8. Reinstall the upper rear cover.

- NOTE:** The On-line key on the operation panel is enabled automatically when the UC5E and interface kit are installed.

4. OPERATION VERIFICATION

Operation verification of the UC5E consists of using the UC5E with a computer and a PRIPORT to verify that all I/O ports function properly.

4.1 TOOLS

The following items are needed to perform an operational verification of the UC5E.

- 1) A Priport
- 2) A UC5E and all items parts
- 3) A PC running any of the specified operating systems listed in 1.1. of this manual.

4.2 TESTS

Verification of correct operation of all ports and status lights verifies that the UC5E is operating normally. Refer to Activity Indicator in the Installation manual.

4.2.1 PRELIMINARY VERIFICATION OF PRIPORT AND VIDEO INTERFACE OPERATION

- 1) Verify that the following parts are properly connected:
 - a) I/F Board to the Priport Main Board (IPU Board), Model C237 only
 - b) Shielded Cable to the I/F Board, Model C237 only
 - c) All other parts of the I/F Kit. Model C237 only
- 2) Turn the Priport on and, while it is offline (i.e., Online OFF is selected), verify that,
 - a) It can produce a good master from a scanned original, and
 - b) It can print from the master made of the scanned original.
- 3) Enable the "Online Mode" while the Priport is in the SP-MODE, and verify that the
 - a) The Online LED illuminates when the Online Key is pressed, and
 - b) No error is displayed on LCD of Priport. If so, recover from the error.

4.2.2 PROCEDURE TO VERIFY UC5E POWER ON SEQUENCE AND PRIPORT INTERFACE

- 1) This verification can only be done once installation is complete.
- 2) Put the Priport ONLINE.
- 3) Wait while the UC5E conducts its turn-on self-diagnostic test (takes about 6 seconds.)
- 4) Check the UC5E LED status lights:
 - a) The right red light stays on when the power-on switch is processed.

- b) The left red LED flashes for approximately 6 seconds, and is the Rip activity LED
- c) The UC5E is ready, for printing when the self-diagnostic test is finished and the left red light goes out.

NOTE: A solid left red status light with the right status light off verifies correct UC5E power on process.

- 5) When the UC5E is ready for printing, put paper into the Priport input tray and setAuto Cycle ON.
- 6) Press the Test Page button, "T" on the keypad . The right red light will start to flash quickly, indicating the UC5E is in the process of creating a Test Page.
- 7) Master making should begin when the right red light stops on.
- 8) Printing should begin when the right red light stops on.

NOTE: A correctly generated/printed Test Page verifies correct operation of the UC5E's digital duplicator port.

4.2.3 PROCEDURE TO VERIFY THE UC5E'S PARALLEL PORTS

- 1) If not previously done, perform operation verification procedures 4.2.1 and 4.2.2.
- 2) Connect a parallel cable such as that supplied in UC5E Kit between the PC and the Priport.
- 3) If not previously done, install the UC5E drivers onto the PC. Make sure to install the printer drivers specific to the digital duplicator (Priport) model with which you are working. Make sure the port to which the printer is attached is LPT1:.
- 4) Select the printer driver for the Priport and print the Windows Test Page from the Printer Properties of the printer driver:
 - a) Put paper into the input tray of the Priport and setAuto Cycle on,
 - b) In the Printers Folder, right-click on the Priport printer driver, select Properties, then locate and click on Print Test Page,

NOTE: A correct printout of the Windows Test Page verifies correct operation of the UC5E's parallel port.

5. TROUBLESHOOTING

5.1 BASIC STEPS FOR TROUBLESHOOTING

5.1.1 CATEGORIZING PROBLEMS

When a problem is reported, it should be categorized according to the data or information collected from the customer regarding its occurrence. This data falls into three categories:

- 1) the steps required to generate the problem,
- 2) the conditions under which the problem occurs, and
- 3) the frequency of occurrence.

The process of categorization should proceed as follows:

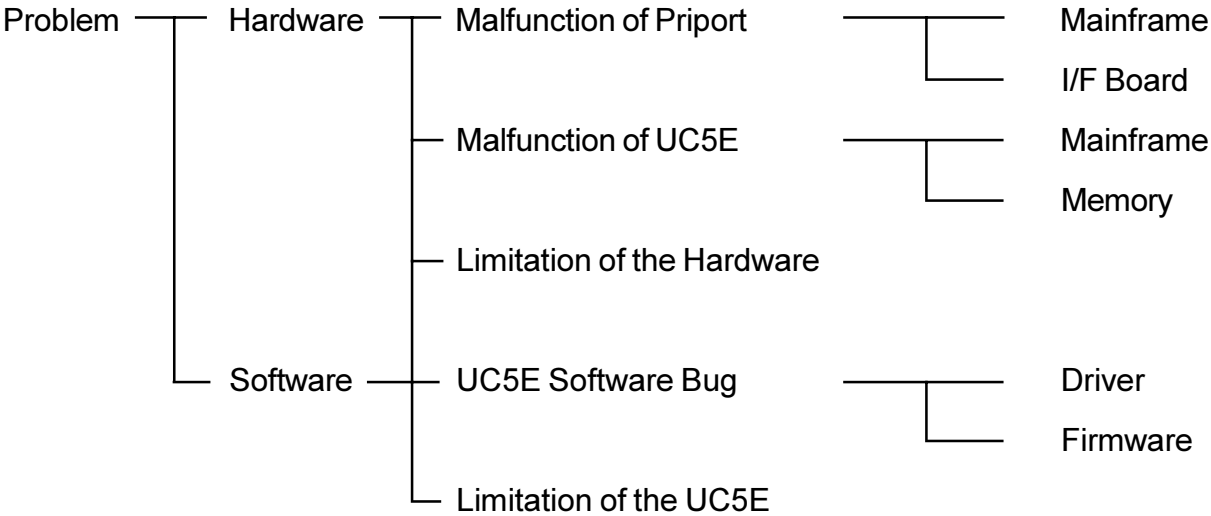

5.1.2 EQUIPMENT NECESSARY FOR TROUBLESHOOTING

The following items are needed, as well as a working Priport and Win95/98 computer.

NOTE: The following items are available as the UC5E Kit. Refer to section 7 for the part number.

- 1) Cables for operational verification of the UC5E.
 - a) 1, PRIPORT-to-UC5E video cable.
 - b) 1, computer-to-UC5E parallel cable.
- 2) Installation CDROM (all mfr Installation CDs) allowing setup of any PRIPORT and any UC5E model number.

5.1.3 INFORMATION NECESSARY FOR TROUBLESHOOTING

The following information should be collected before troubleshooting begins:

- A Test Page from the UC5E,
- The name and version of the printer driver, and firmware version,
- A print sample showing the problem,
- The printer settings of the computer, and
- The name and version of the application software that generated the page.

5.2 TROUBLESHOOTING FLOW

5.2.1 TROUBLESHOOTING FLOWCHART

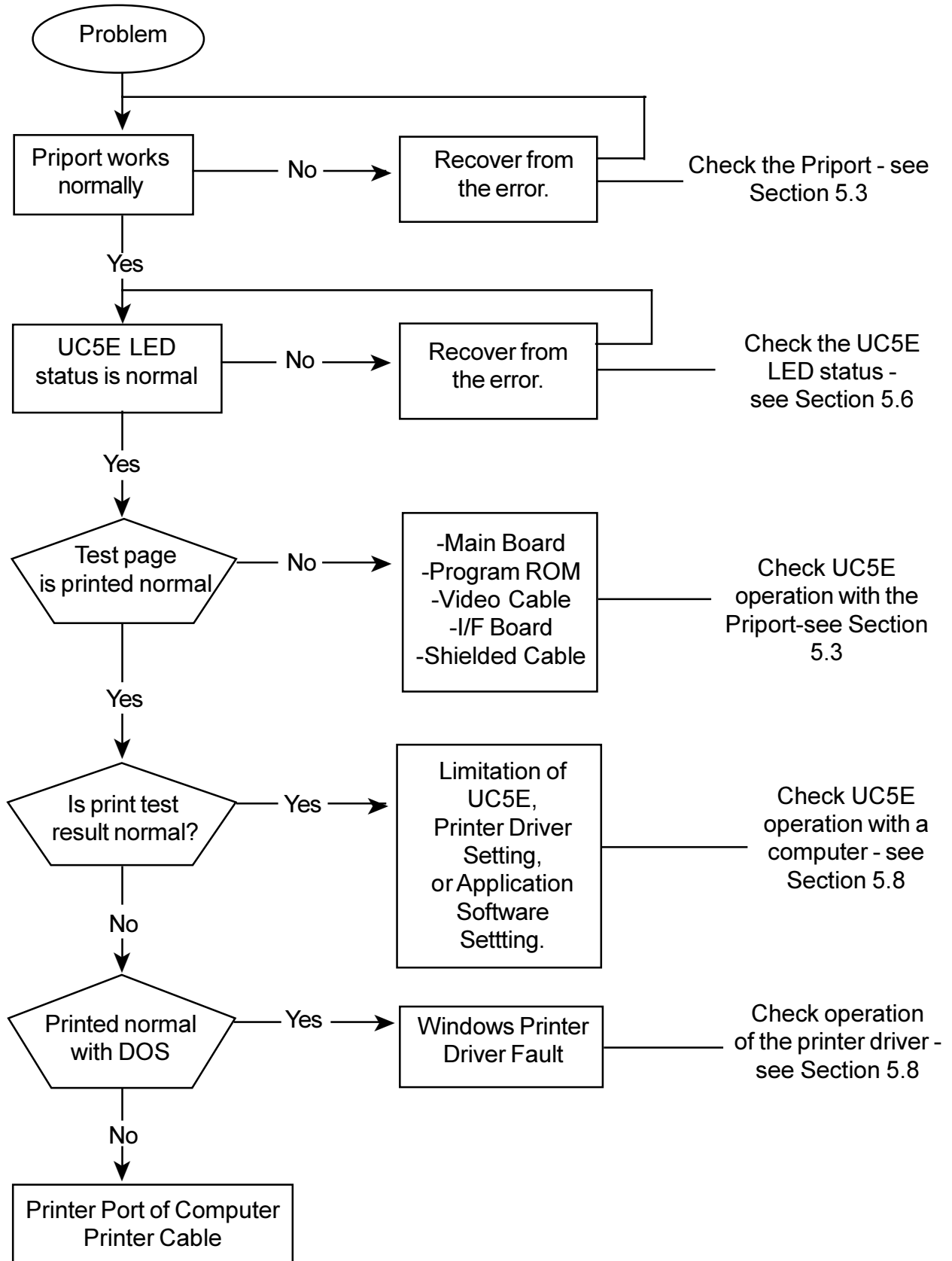

5.3 PRIORT/UC5E FAILURE IDENTIFICATION

For each of the following failure modes, see the corresponding operation verification procedure to assist with the troubleshooting process:

Apparent Failure Mode	Operation Verification Procedure
Priort operation <i>without the UC5E</i>	Section 4.2.1
Priort/UC5E operation <i>without a computer.</i>	Section 4.2.2
Priort/UC5E operation <i>with a computer.</i>	For operation with a PC: Section 4.2.3.

Use the operation verification procedure indicated to help identify in which component the problem lies.

5.4 SUBASSEMBLY TROUBLESHOOTING

Once you have positively identified a problem with the UC5E, it will be necessary to troubleshoot the problem to the assembly level, and replace the faulty assembly.

5.4.1 IDENTIFYING THE FAULTY ASSEMBLY

A problem or fault must be traced to one of the subassemblies of the UC5E. As a general rule, it is best to check the subassemblies in order according to their respective expected failure rates, keeping in mind the failure symptoms. Therefore it is generally recommended that the boards be checked in the following order:

- 1) The 16MB SIMM
- 2) The Main Board itself

IMPORTANT: The procedures to identify in which component the problem lies may be used to verify the operation of the indicated subassembly. If operation of any particular subassembly cannot be verified, replace the entire subassembly – do not attempt component-level repair.

5.5 MEMORY TROUBLESHOOTING

For the memory replacement, refer to section 6.5.

5.6 LED STATUS LIGHT SEQUENCE AND CONDITIONS

5.6.1 EVENT: POWER ON AND ACTIVATION

Status	Contents	Check Point
All LEDs are off.	No power supply	<ul style="list-style-type: none"> No AC power, AC cord not properly connected, or power supply failure in the UC5E.
LEFT Red LED is flashing	Self-diagnostic test before ready	<ul style="list-style-type: none"> 1 Quick flash & no of flashes for version of firmware. Right RED LED is on
Right Red LED is on	Power on.	_____
LEFT Red LED is flashing rapidly	UC5E is receiving data.	<ul style="list-style-type: none"> Check to see if there is a print job in the print queue of the network server, the print manager, or the print spooler in computer (option)
LEFT Red LED is on continuously	UC5E is transferring data / making a master.	<ul style="list-style-type: none"> Check to see if there is a print job in the print queue of the network server, the print manager, or the print spooler in computer.(option)
LEFT RED LED Is continuously off	The UC5E is idle	_____
LEFT Red LED flashing slowly and evenly	Error on Priport	<ul style="list-style-type: none"> Check message on operation panel.

5.6.2. EVENT: PUSH THE DIAGNOSTIC TEST PAGE BUTTON

Status	Contents	Check Point
LEFT Red LED is flashing.	Receiving data	
LEFT Red LED is on	Master making.	
LEFT Red LED continuously on	Printing.	
LEFT Red LED flashes on then off. Stays off.	No response from the PRIPORT.	<ul style="list-style-type: none"> • Check to see that the PRIPORT is turned on. • Check to see that the UC5E is properly connected to the PRIPORT. • Turn the PRIPORT on first, then turn on the UC5E. • Check to see that the PRIPORT is Online. • Check 16MB Simm card is positioned correctly
LEFT Red LED is flashing slowly and evenly	PRIPORT Error.	<ul style="list-style-type: none"> • Check for an error message on the PRIPORT. • Check to make sure the UC5E is properly connected to the PRIPORT.

5.8 CHECKING PRINTER DRIVER OPERATION

If the Windows Test Page does not print, or doesn't look right, check printer driver operation using the following steps.

- 1) Select the Details tab in the Properties Menu of the Printer Driver,
- 2) Change Port connection to "File :",
- 3) Click on the Apply button, select the General Tab and click on the Print Test Page button,
- 4) Set the file name (e.g., "test"), set the disk/directory location, and save the file,
- 5) Click 'YES' when the message pops up asking whether the test page printed correctly,
- 6) Open an MSDOS session (Start-Programs-MSDOS Prompt).
- 7) Check that the Priport and UC5E are ready for printing, then execute the following command at the MS DOS Prompt.

```
copy /b test.prn lpt1 "entre"
```

- NOTE:**
- a) Always input "/b" after "copy".
 - b) The above example is if the file name saved in the step d) is "test.prn".
 - c) If the UC5E is connected to the second port of the computer, replace "lpt1" with "lpt2."

- 8) Input "exit" and exit from MS DOS prompt.
- 9) If the image is printed correctly, reset the printer driver to print to the printer port by doing the following:
 - a) select the Details tab in Properties Menu of the Printer Driver
 - b) change the Port back to the original setting (e.g., LPT1: or LPT2:),
 - c) click Apply.

Failure to do this will result in subsequent print jobs using this printer driver will be sent to a file on the hard drive instead of the printer.

If the image did not print correctly, there is a problem with the printer driver – it may be corrupt or out-of-date. Delete the printer driver and replace with a version from the Installation CD. Then repeat this process.

5.9 COLLECTING INFORMATION FOR A PROBLEM REPORT

The Problem Report should include the following items:

- A Diagnostic Test Page printed by the UC5E.
- The name of computer manufacturer, and the model.
- The type of CPU, CPU speed and number of megabytes of RAM in the computer.
- The model name and number of the PRIPORT.
- The name and version of the printer driver being used.
- The port to which the Printer Driver is connected (i.e. LPT1).
- The EPROM version of the PC Controller I/F Kit Printed Circuit Board (for the JP series, the serial number of the Priport).
- The flashing pattern of both the UC5E status lights at time the problem is observed.
- The name and version of the application software (i.e., Microsoft Word 97, Adobe PageMaker, etc.).
- The paper size and orientation selected in the application software's Print menu.
- A sample printout showing the problem

6. DISASSEMBLY / ASSEMBLY

6.1 REQUIRED TOOLS AND PRECAUTIONS

- Anti-static wrist strap.
- #1 Phillips screwdriver.
- 1 Flathead screwdriver

DANGER

The UC5E's power supply becomes hazardous with the chassis opened. It exposes you to severe electrical shock if you do not disconnect the power cord before opening.

CAUTION

The electronic components in this unit can be damaged by static discharge. Please ensure that you are properly grounded before touching any portion of the electronics. Also, touch the chassis with your finger before connecting test cables, setting switches or reattaching components.

6.2 ZIPRIP FOR MODEL C237

(Refer to page 5 for the Driver Groups)

Tools required:-

- a. Phillips screw driver
- b. Flat head screw driver
- c. Antistatic equipment

Discard the following parts for this installation:-

- a. Part No. VU5E05301
- b. Part No. VU5E05404
- c. Part No. VU5E05402
- d. Part No. VU5E10002

Installation Time:-

This installation should take 30 minutes excluding the time taken to install the video board.

1. Turn off the main switch and unplug the power cord.
2. Remove your UC5E and ancillary items from the box.
3. Open the scanner unit.
4. Remove the upper rear cover.
5. Remove the rear cover.
6. Remove the MPU cover.

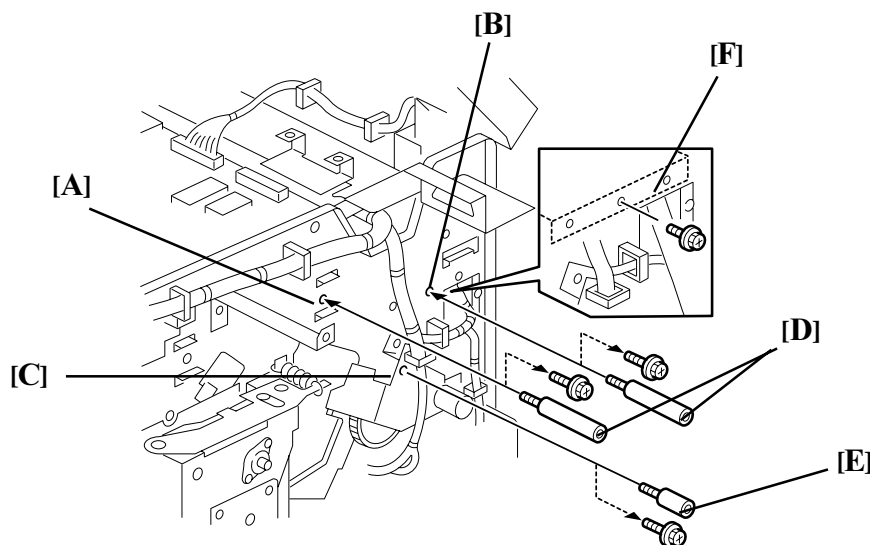

Figure 2a.

7. Remove screws [A], [B] and [C]. Keep them aside for later use.
8. Locate the three standoffs supplied. Mount them into the holes as follows:
Into hole marked [A] in Figure 2a screw in the 45mm standoff [D].
Into hole marked [B] in Figure 2a screw in the 45mm standoff [D].
Into hole marked [C] in Figure 2a screw in the 26mm standoff [E].

NOTE:

- 1) Tighten these standoffs with a flat screwdriver.
- 2) The bracket [F] becomes free without screw [B]. Hold bracket [F] by the hand until you screw in standoff [D].

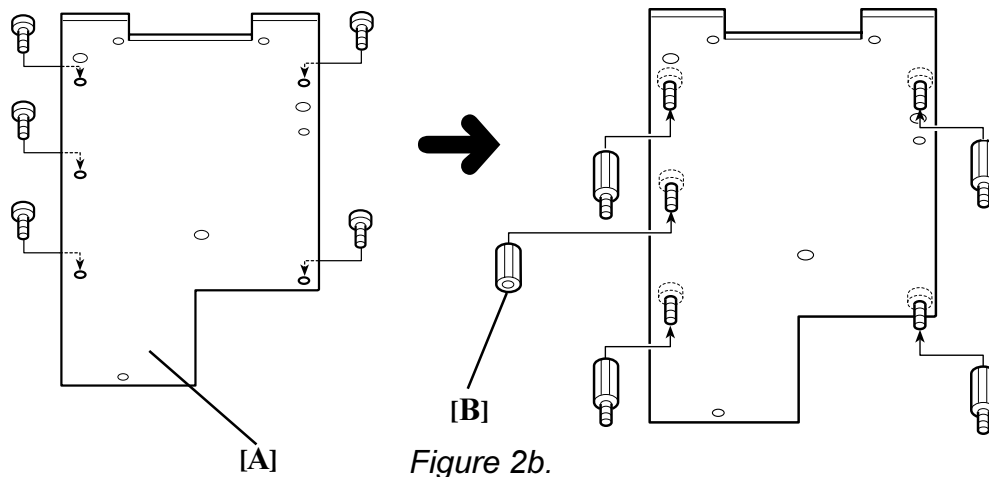

Figure 2b.

9. Locate the mounting plate [A], part no. VU5E 05 406. Orientate the plate correctly, as shown.
10. Attach five “M3 x 6mm screws” on the mounting plate [A], then attach four “M3 x 10mm male to female standoffs” and one “M3 x 10mm female to female standoff” [B].

NOTE:

There are three different size holes on the mounting plate [A]. Use 5 of the 6 small tapped holes, and the other holes are not used.

(See Figure 2b)

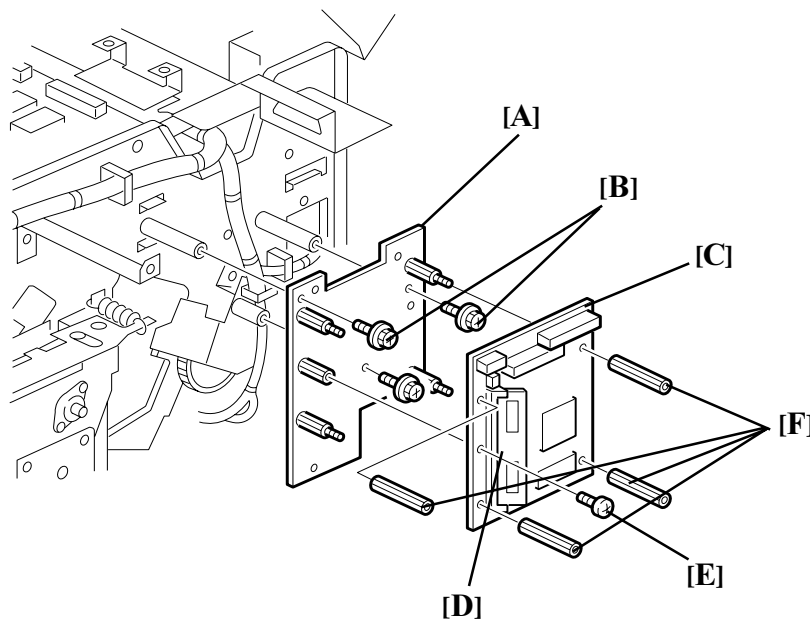

Figure 2c.

11. Place the assembled mounting plate [A] onto the standoffs on the chassis and secure using the three M4 screws [B] set aside in step 7.
12. Locate the UC5E main board [C], Part No. VU5E 05 200.

CAUTION:

THIS PART IS VERY SENSITIVE TO STATIC.

PLEASE ENSURE THE CORRECT ANTISTATIC PRECAUTIONS ARE TAKEN.

The RAM SIMM [D] should be on the left.

13. Secure the main board by screwing in a M3 x 6mm screw [E] into the left middle standoff.
14. Install four “M3 x 25mm female to female standoffs” [F].

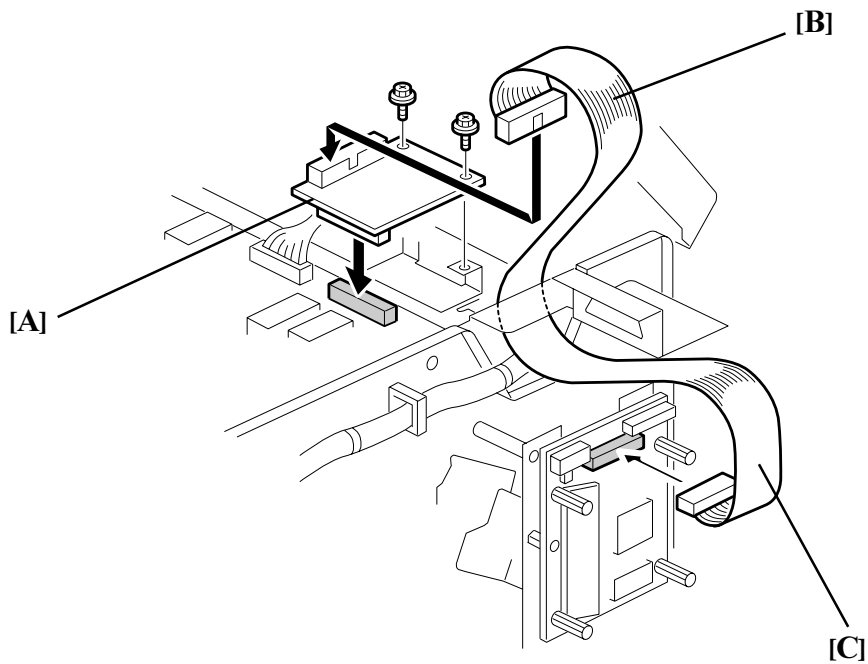

Figure 2d.

15. Install the interface board [A] from the package of Video Interface Kit Type-10 (Use the two M3 x 6mm screw from the package).
16. Locate the 26-pin MPU cable [B] Part No. VU5E 05401, and connect the 26 pin twisted end [C] to the UC5E main board middle connector and the straight end to the interface board.

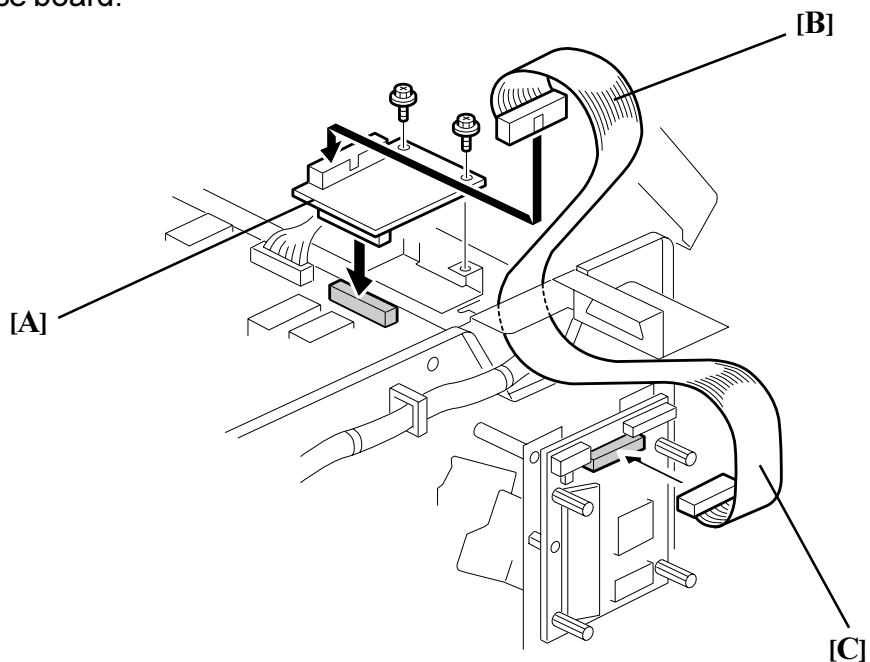

Figure 2d.

15. Install the interface board [A] from the package of Video Interface Kit Type-10 (Use the two M3 x 6mm screw from the package).
16. Locate the 26-pin MPU cable [B] Part No. VU5E 05401, and connect the 26 pin twisted end [C] to the UC5E main board middle connector and the straight end to the interface board.

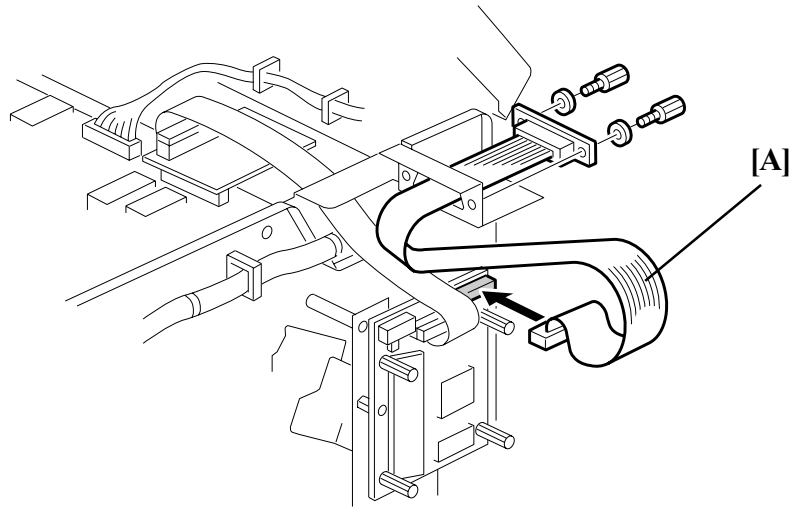

Figure 2e.

17. Locate the cable [A] Part No. VU5 05410, and connect the 26 pin ribbon cable end to the outer connector on the UC5E main board. The DB 25 end is connected to the DB25 cut out on the chassis of the main frame using the two M3 x 5mm jack posts supplied in the IF Kit Type-10.
18. Reinstall the MPU Cover, the rear cover and then the upper rear cover of the Digital Duplicator.

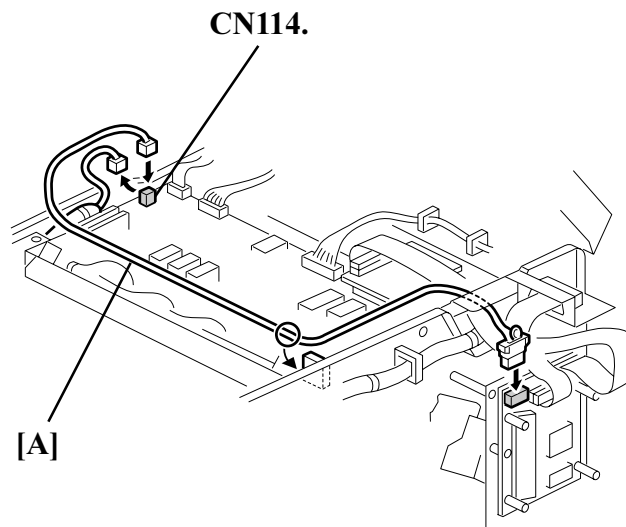

Figure 2f.

19. Disconnect the connector on CN114.

NOTE:

It is not necessary to remove the cable from the machine as it becomes redundant.

20. Locate the red and black power cable [A], Part No. VU5E 05300. Connect this cable CN114 on the MPU of the Digital Duplicator and J4 connector on the UC5E main board.

NOTE:

Secure the RED and BLACK power cable to the loom running along the MPU with the 4 cable ties supplied, ensuring that the cable and the loom does not catch on the MPU cover.

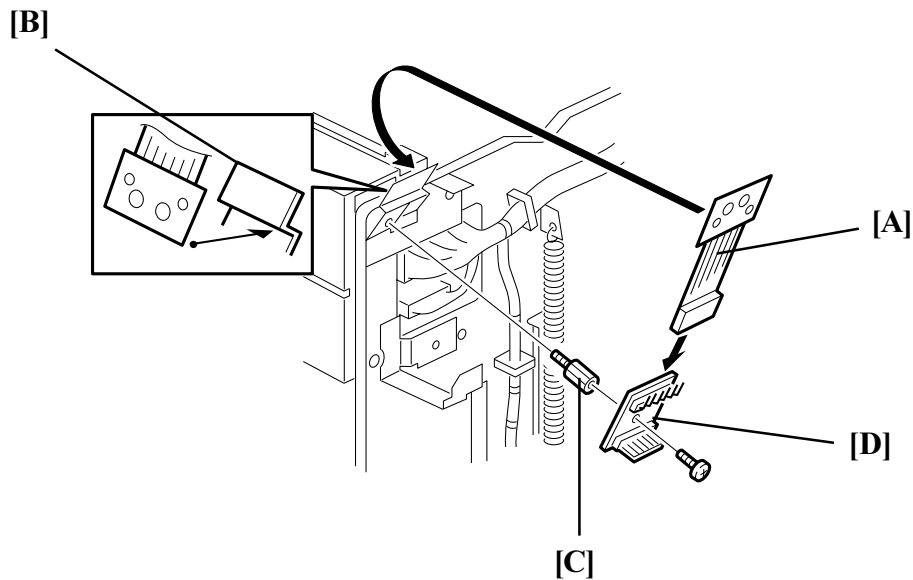

Figure 2g.

21. Locate the Marguard LED and button assembly [A], part number VU5E10010. Peel the plastic of the back of the Marguard LED and button assembly [A] and stick it onto the bracket [B] of the Digital Duplicator.
22. Secure the keypad M3 x 10mm standoff [C], then mount the keypad PCB [D] onto the standoff [C] using a M3 screw.
23. Connect the marguard cable into the flat connector on the Keypad PCB [D].

NOTE:

- 1) Make sure the marguard is positioned correctly on bracket so that it can be seen through the upper rear cover cutout.
- 2) The button connectors have no polarity therefore they can be connected in either way.

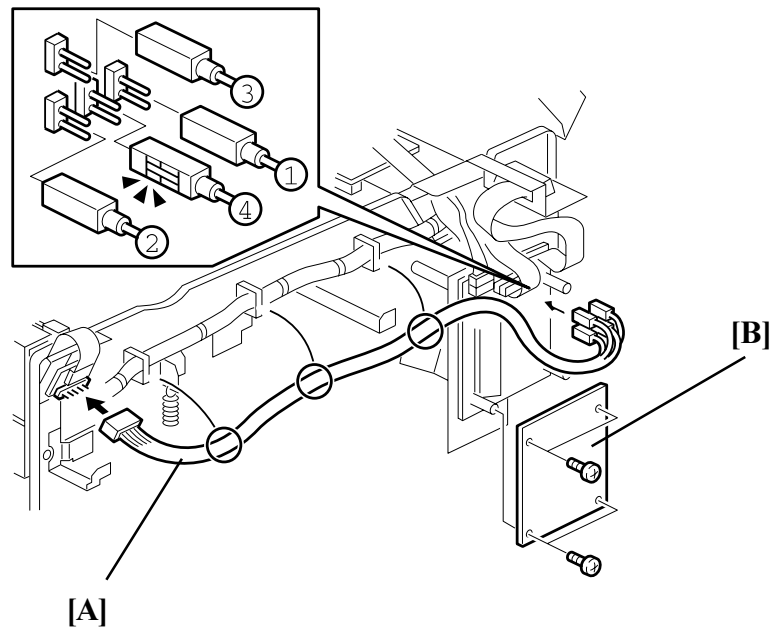

Figure 2h.

24. Locate the 8 pin ribbon cable [A], part number VU5E10001. Connect the white pin connector onto the keypad PCB and the 4 x 2 pin connectors onto the UC5E main board.

NOTE:

Connectors 1 & 4 are sensitive to polarity. These connectors should be plugged in with the viewable pin sides (2 x gold coloured pins) facing outwards and the solid sides facing each other.

25. Mount the plate cover [B] onto the standoffs on the UC5E main board and secure with four "M3 screws" supplied.
26. Plug in the power cord and switch on the Digital Duplicator.
27. The RIGHT RED LED on the membrane panel will come on and the LEFT RED LED will flash according to the version of software in the UC5E main board. eg: 5 flashes for version 5.
28. Press the "T" on the marguard LED and button assembly and the Digital Duplicator will print a test page. Refer to troubleshooting section if no test page is printed.

6.3 ZIPRIP FOR MODEL C235

(Refer to page 5 for the Driver Groups)

Tools required:-

- a. Phillips screw driver
- b. Flat head screw driver
- c. Antistatic equipment

Discard the following parts for this installation:-

- a. Part No. VU5E06300
- b. Part No. VU5E05403
- c. Part No. VU5E05405
- d. Part No. VU5E10001
- e. Part No. VU5E05401

Installation Time:-

This installation should take 30 minutes excluding the time taken to install the video board.

1. Turn off the main switch and unplug the power cord.
2. Remove your UC5E and ancillary items from the box.
3. Remove the rear cover.

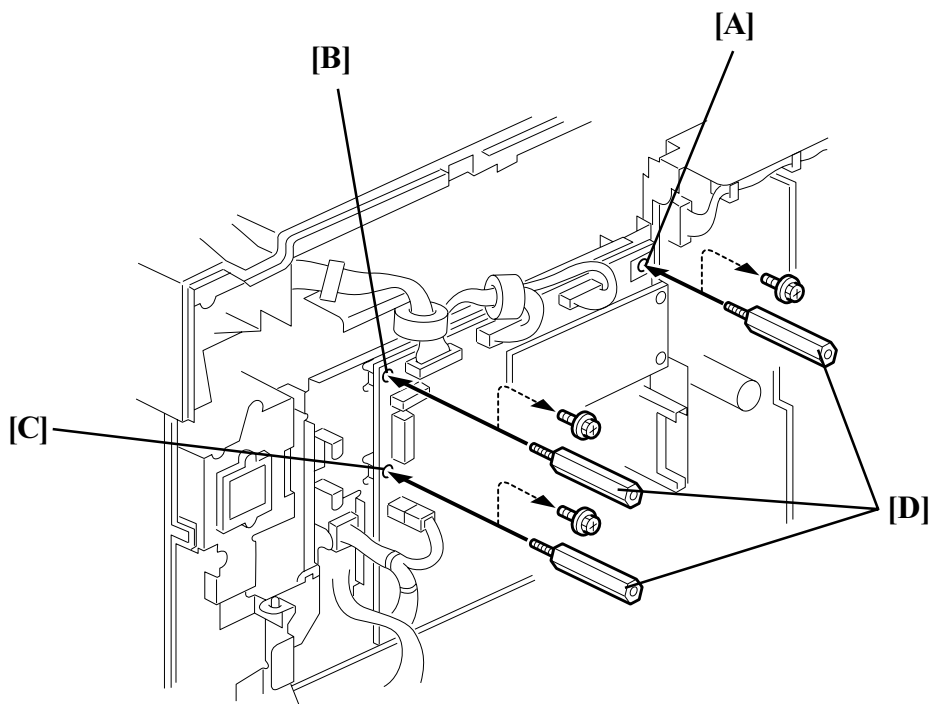

Figure 3a.

4. Remove screws [A], [B] and [C]. Keep them aside for later use.
5. Locate the three M3 x 35mm standoffs [D] supplied. Mount them into the holes.

NOTE:

Care must be taken not to damage the Digital Duplicator MPU

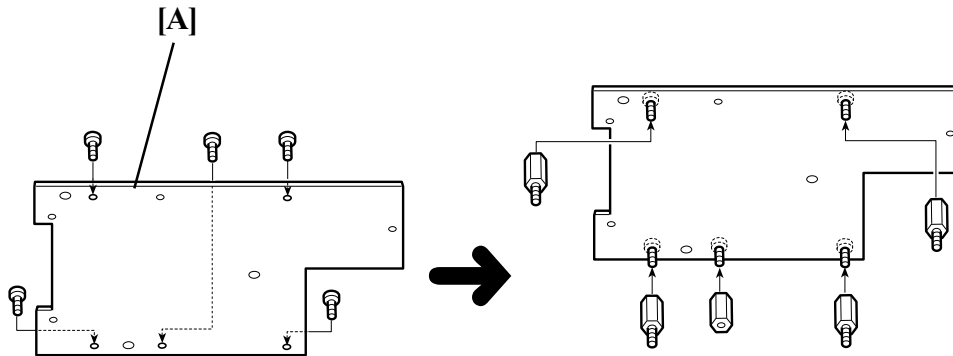

Figure 3b.

6. Locate the mounting plate [A], part no. VU5E 05 406. Orientate the plate correctly, as shown.
7. Attach five “M3 x 6mm screws” on the mounting plate [A], then attach four “M3 x 10mm male to female standoffs” to the outer screws and a “M3 x 100mm female to female” standoff to the middle screw.

NOTE:

There are three different size holes on the mounting plate [A]. Use 5 of the 6 small tapped holes, and the other holes are not used.

(See Figure 3b)

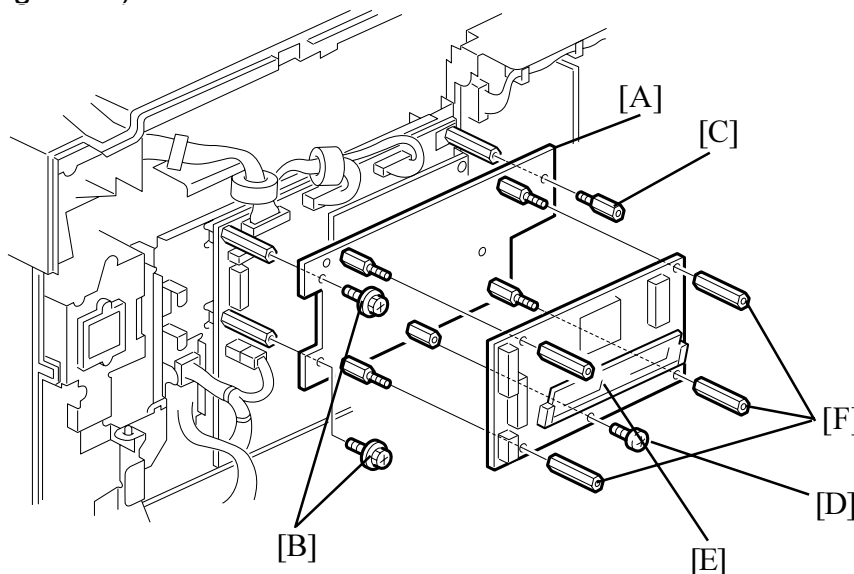

Figure 3c.

8. Place the assembled mounting plate [A] onto the standoffs on the chassis and secure using the three M4 screws [B] set aside in step 4.
9. Locate a M3 x 10mm standoff and screw it through the mounting plate into the standoff [C].
10. Locate the UC5E Main Board, Part No. VU5E050200, and secure it by screwing in a M3 x 6mm screw [D]

CAUTION:

THIS PART IS VERY SENSITIVE TO STATIC.

PLEASE ENSURE THE CORRECT ANTISTATIC PRECAUTIONS ARE TAKEN.

The RAM SIMM [E] should be on the bottom.

11. Install four “M3 x 25mm female to female standoffs” [F].

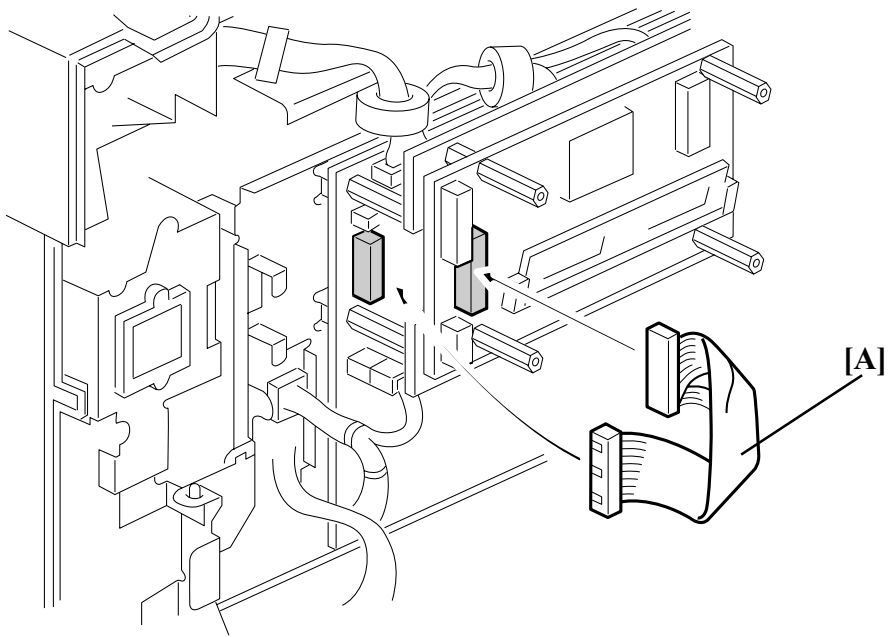

Figure 3d.

12. Locate the 26-pin MPU cable, Part No. VU5E05402 [A], and connect the 26 pin twisted end to the UC5E main bord middle connector and the other straight end to the Digital Duplicator MPU.

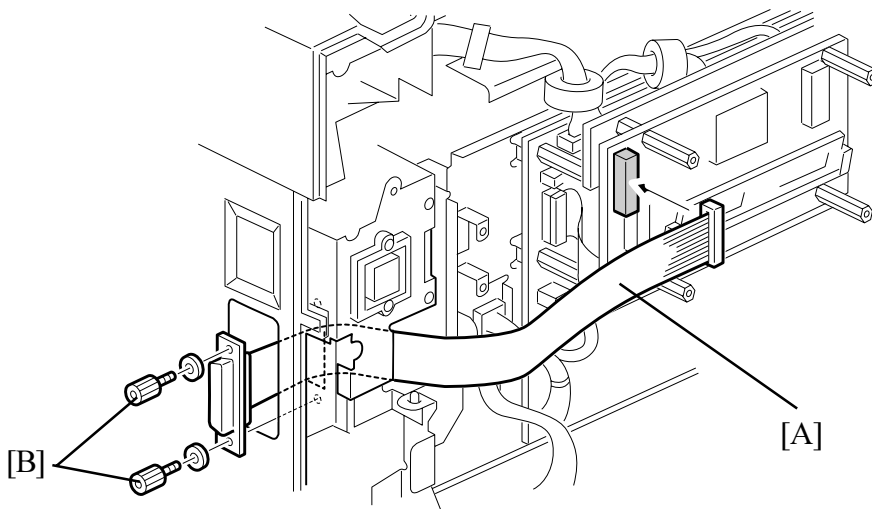

Figure 3e.

13. Locate the 26-pin to 25-pin ribbon PCB to cover cable [A], part number VU5E05410, and connect the 26 pin ribbon cable end to the outer ribbon plug on the UC5E main board. The DB25 end is connected to the DB25 cutout on the side chassis of the Digital Duplicator using the two M3 x 5mm jack posts [B].

NOTE:

If a DB25 end cable is originally installed in the machine, remove it before installing the cable [A]. Reuse the two M3 x 5mm jackposts originally installed in the machine.

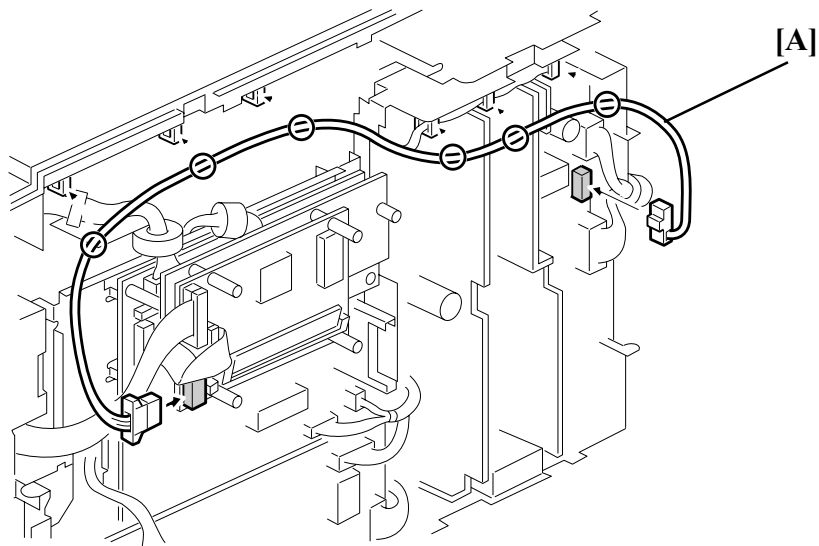

Figure 3f.

14. Locate the 2 pin power cable [A], part number VU5E 05 301. Connect the 4 pin side of the cable into the power plug on the UC5E main board. Connect the other end into connector CN702 of the Digital Duplicator.

NOTE:

Ensure the slack is taken up evenly on the power cable through out it's length from the PSU to the UC5E main board.

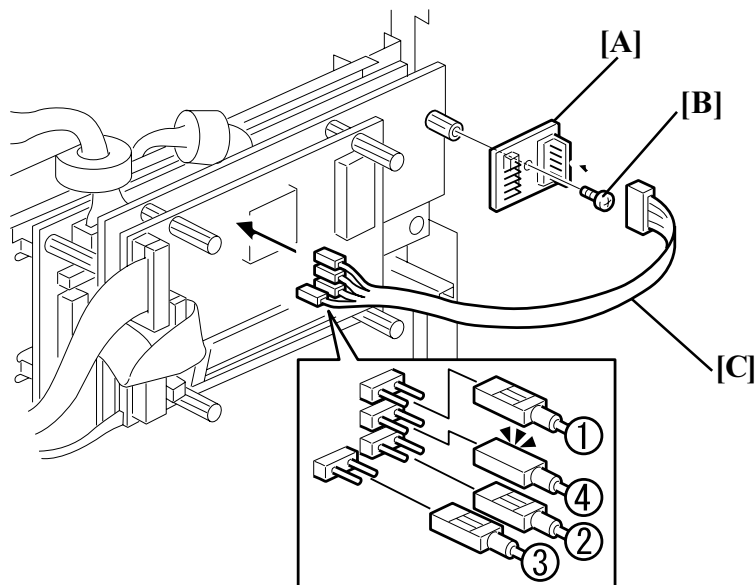

Figure 3g

15. Mount the keypad PCB [A], part no. VU5E10 005 onto the standoff on the right and secure with a M3 x 6mm screw [B] supplied.
16. Locate the 8 pin ribbon cable [C], part number VU5E 10 002. Connect the white pin connector end to the upright connector on the keypad PCB and the loose 4 x 2 pin connectors onto the UC5E main board.

NOTE:

Connectors 1 & 4 are sensitive to polarity. These connectors should be plugged in with the viewable pin sides (2 x gold coloured pins) facing outwards and the solid sides facing each other.

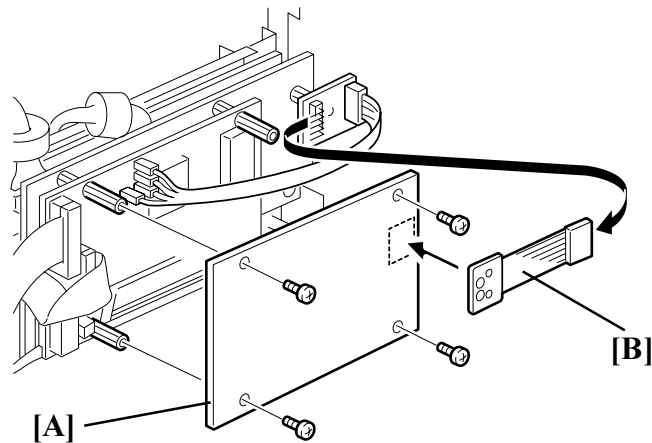

Figure 3h.

17. Place the mounting plate cover [A] onto the standoffs on the UC5E main board and secure with four "M3 screws" supplied.
18. Stick the marguard LED and button assembly [B] onto the outside top right of the cover plate.

NOTE:

The button connectors have no polarity therefore they can be connected in either way.

19. Plug in the power cord and switch the Digital Duplicator on.
20. Press the "T" on the marguard and the Digital Duplicator will print a test page.
21. Turn the Digital Duplicator off and unplug the power cord.
22. Reinstall the rear cover.
23. Turn on the Digital Duplicator power switch.

6.4 UPGRADING UC5E FIRMWARE

6.4.1 MAIN BOARD FIRMWARE UPDATE INSTRUCTIONS

- 1) The firmware (resides in an on-board FLASH ROM chip on the Main Board).
The instructions below describe the procedure to perform this update.
Loaded Firmware Revision is indicated at power up by the number of rapid flashes after the initial slow flash.

6.4.1.1 PREPARE THE UC5E AND COMPUTER.

DANGER

The UC5E's power supply becomes hazardous with the chassis opened. It exposes you to severe electrical shock if you do not disconnect the power cord before opening.

CAUTION

The electronic components in this unit can be damaged by static discharge. Please ensure that you are properly grounded before touching any portion of the electronics. Also, touch the chassis with your finger before connecting test cables, setting switches or reattaching components.

6.4.1.2 FLASH UPDATE

1. Obtain latest flash file, www.ziprip.com
2. Confirm number of left red LED start up flashes from UC5E
3. Switch of the Digital Duplicator and unplug from the wall
4. Locate the jumper next to the eeprom chip.
5. Put the jumper into the on position.
6. Power up Duplicator.
7. Boot up PC and go into DOS.
8. Use "copy" command to update flash, e.g. copy latest .fla Lpt1: (where Lpt1 is the connected port) Command is copy filename.fl a lpt1 entre.
9. While the flash update is in progress the LEFT RED LED is continuously ON.
10. Wait for Indication that flash has been completed. The LEFT RED LED flashes rapidly.
11. Reset UC5E and confirm the number of start up flashes matches the new firmware version, i.e. 4 flashes means version 4 has loaded.
12. Switch off the UC5E and put the jumper back to the off position. Switch on.

6.5 MEMORY REPLACEMENT

The UC5E is fitted with 16mb RAM as standard. This is more than sufficient to image an A3 at 600 dpi. Faster processing can only be achieved by upgrading the PC that the UC5E is connected to.

The only event that would lead to memory replacement would be if the factory supplied memory were to fail.

RAM Installed: 16mb 72 pin simm.

6.5.1 REPLACEMENT PROCEDURE

- 1) Turn the Priport off and disconnect it from the mains.
- 2) Remove the Mounting Plate Cover.
- 3) Remove the existing RAM SIMM by easing apart the side clips on the SIMM socket.
- 4) Insert the new RAM SIMM. Ensure the correct orientation and make sure the SIMM is correctly held by the retaining clips.
- 5) Replace the Mounting Plate Cover.

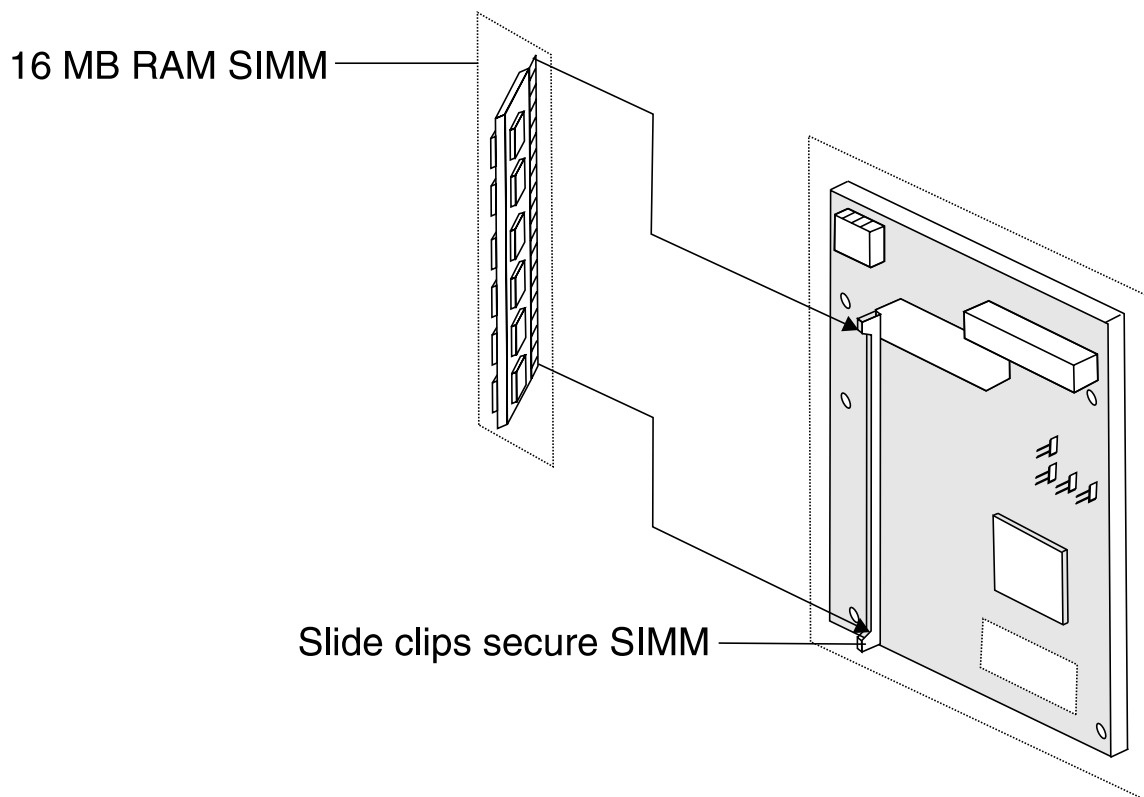

7. PARTS LIST

7.1 UC5E REVISION 11 C235

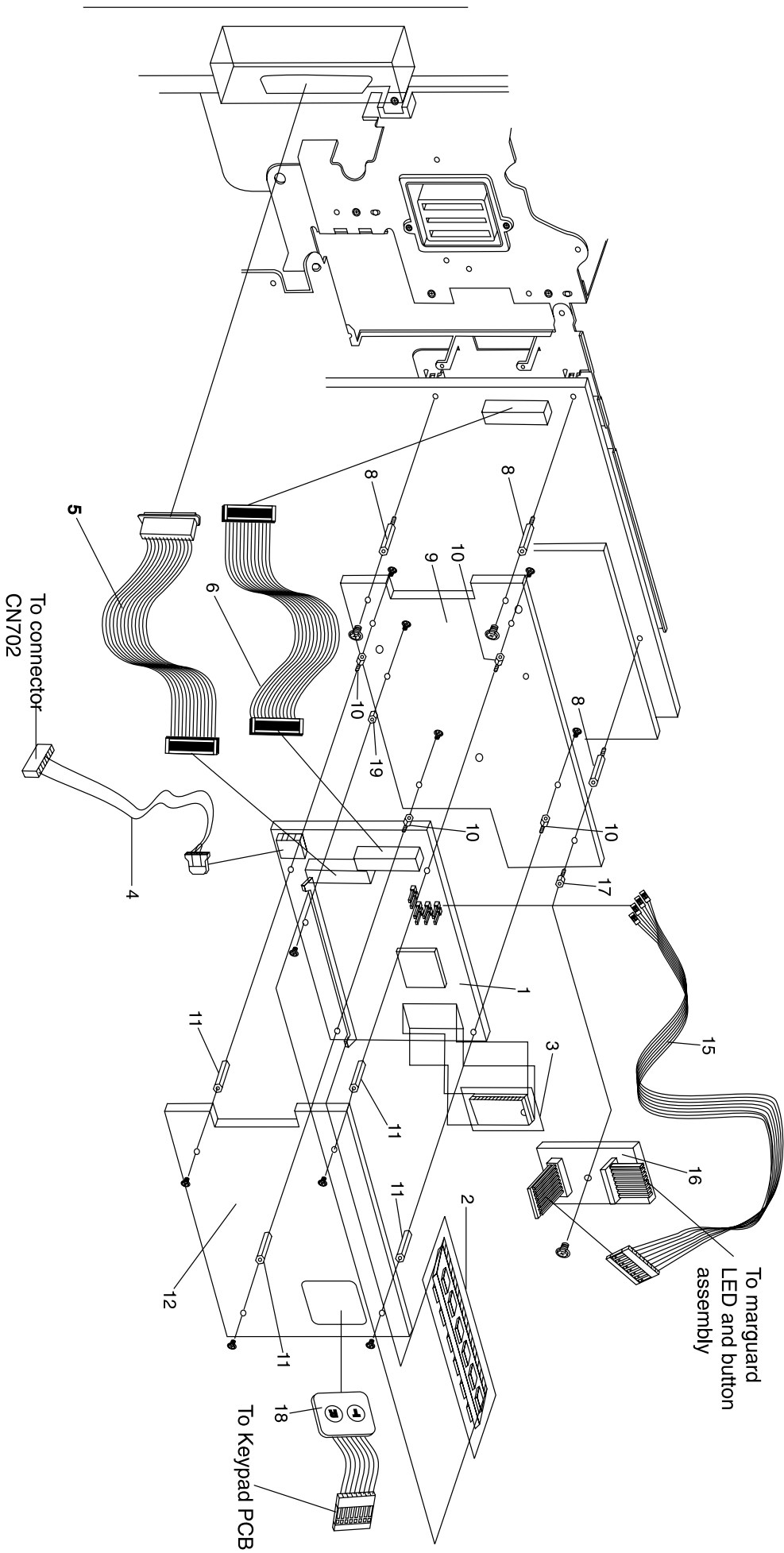

7.2 UC5E REVISION 11 C237

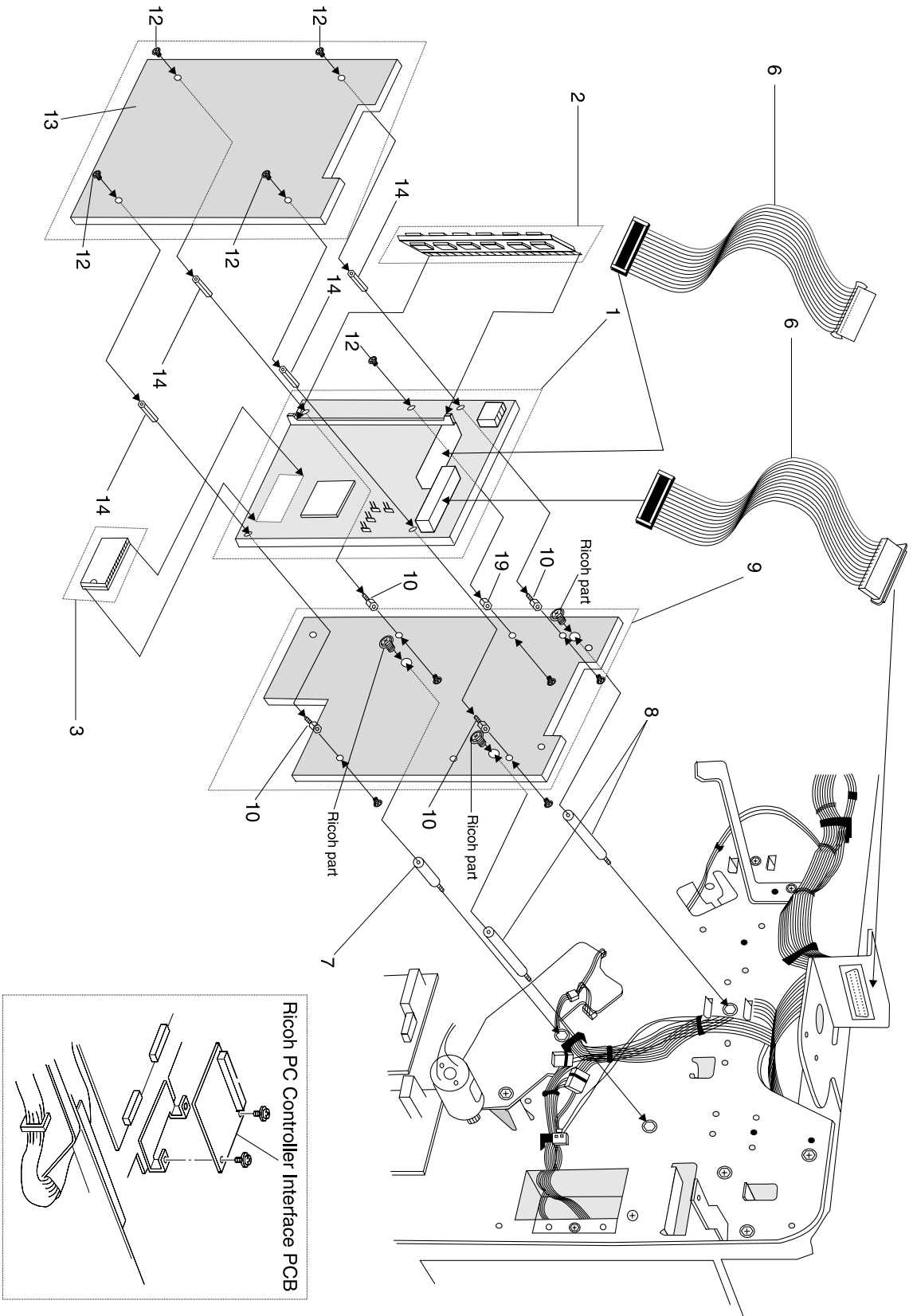

RICOH SPARES PRICE LIST
ZipRip UC5e (Embedded) (VU5E 00 000)
May 15 2001 Rev 16

			Item No	Description	Quan
Main Board Assembly VU5E 05 999	Processor Board Assy VU5E 05 999	VU5E 05 001	1	Board Conformal Coated - discontinued 06/01	1
		VU6E 05 002	1	Board Conformal Coated (Revision June 2001)	1
		VU5S 05 005	2	SIMM 16 MB	1
		VU5E 05 010	3	Flash ROM	1
	VU5E 05 300	4	2-pin cable (Power C237)	1	
	VU5E 05 301	4	2-Pin cable (Power C235)	1	
	VU5E 05 399	4	26-pin MPU Cable (C237 & PG)	1	
	VU6E 05 401	4	26-pin MPU Cable C237 - discontinued 06/01	1	
	VU5E 05 402	6	26-pin MPU Cable C235	1	
	VU5E 05 403	7	Stand Off M4 x 26 mm (C237)	1	
	VU5E 05 404	8	Stand Off M3 x 35mm(C235)	3	
	VU5E 05 405	8	Stand Off M4 x 45 mm (C237 & PG)	3	
	VU5E 05 407	11	Spacer Mounting Plate M3 x 25mm FF	4	
	VU5E 05 406	9	Mounting Plate - discontinued 06/01	1	
	VU6E 05 408	9	Mounting Plate (C235/C237 & Pink Gold)	1	
	VU5E 05 409	12	Mounting Plate Cover	1	
	VU5E 05 410	5	26-pin to 25 pin Ribbon PCB to Cover	1	
	VU5E 05 412	2	Stepping Screw (Ribbon PCB to cover)	2	
	VU5E 05 424	19	Spacer M3 X 10 FF	1	
	VU5E 05 425	10	Standoff (PCB) M3 x 10mm MF	5	
VU5E 05 426	11	Securing Screws PCB M3 x 6mm	11		
Control Button and LED Assy VU5E 10 999	VU5E 10 001	15	8- pin Ribbon Cable C237	1	
	VU5E 10 002	15	8- pin Ribbon Cable C235	1	
	VU5E 10 005	16	Keypad PCB	1	
	VU5E 10 006	17	Standoff Keypad PCB M3 x 10	1	
	VU5E 10 010	18	Marguard LED and button Assy (Red)	1	
	VU5E 10 011	18	Marguard LED and button Assy (Green)	1	
	VU5E 10 050		Cable Tie Black Securing Harness	6	
VU5E 00 999 Assembly	VU5E 05 999		Main Board Assembly	1	
	VU5E 10 999		Control Button & LED Assembly	1	
	VU5E 00 050	12	PC Parallel Cable (M to M)	1	
	VU5E 00 065	13	CD	1	
	VU5E 00 075	14	Manual English or	1	
	VU5E 00 077	14	French or		
	VU5E 00 078	14	German or		
	VU5E 00 079	14	Italian or		
	VU5E 00 080	14	Spanish		
	VU5E 00 089		Label	1	
VU5E 00 090		Printed Carton	1		

7.3. PC CONTROLLER I/F KIT TYPE-10

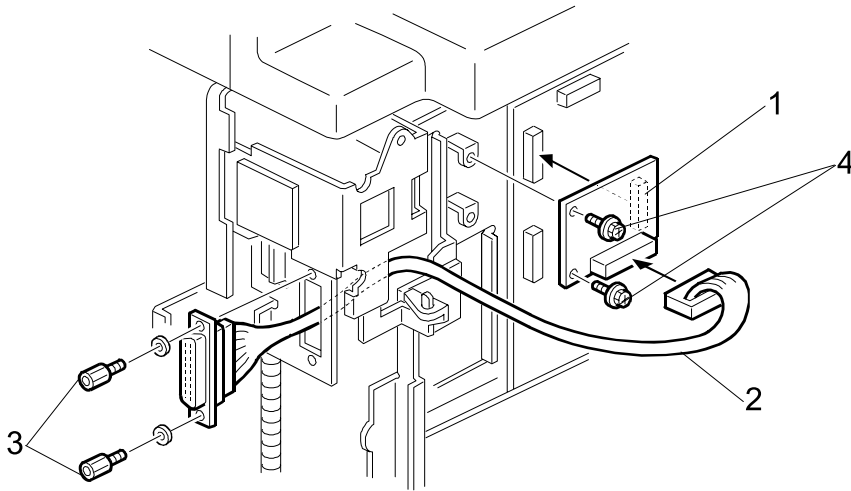

Model C237

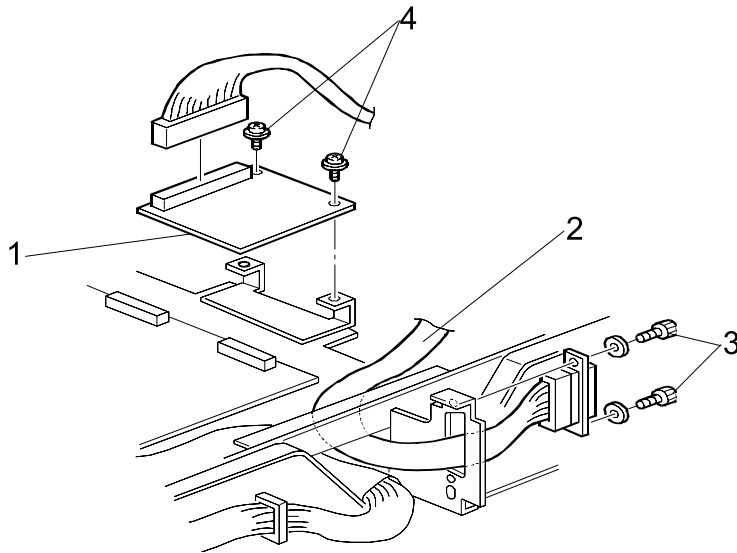

Index No.	Part No.	Description	Q'ty Per Assembly
1	C580 1011	Interface Board	1
2	C580 1500	Relay Harness	1
3	C580 1550	Stepped Screw – M2.6	2
4	0451 3006B	Tapping Screw – M3 x 6	2

1.4 VIDEO INTERFACE KITS

Description	Contents
PC Controller I/F Kit Type-10	For the connection to Model C235 and Model C237

Table 1.4. Interface Kits for use with the UC5E.



3. VIDEO I/F INSTALLATION PROCEDURES

3.1 VIDEO I/F KIT TYPE-10 PARTS LIST

No.	Description	Qty.
32	Interface Board	1
33	Relay Harness	1
34	Stepped Screw – M2.6	2
35	Tapping Screw – M3 x 6	2

Table 3.2.1. Video I/F kit Type-10.

3.2 INSTALLATION PROCEDURES FOR INTERFACE KITS

- NOTE:**
- 1) The UC5E Controller is designed for the Model C237 and Model C235 range of Digital Duplicators.
 - 2) Numbers in parentheses () in the installation procedures correspond to the part numbers in Tables 3.1.

3.2.1 MODEL C237

1. Turn off the main switch and unplug the power cord.

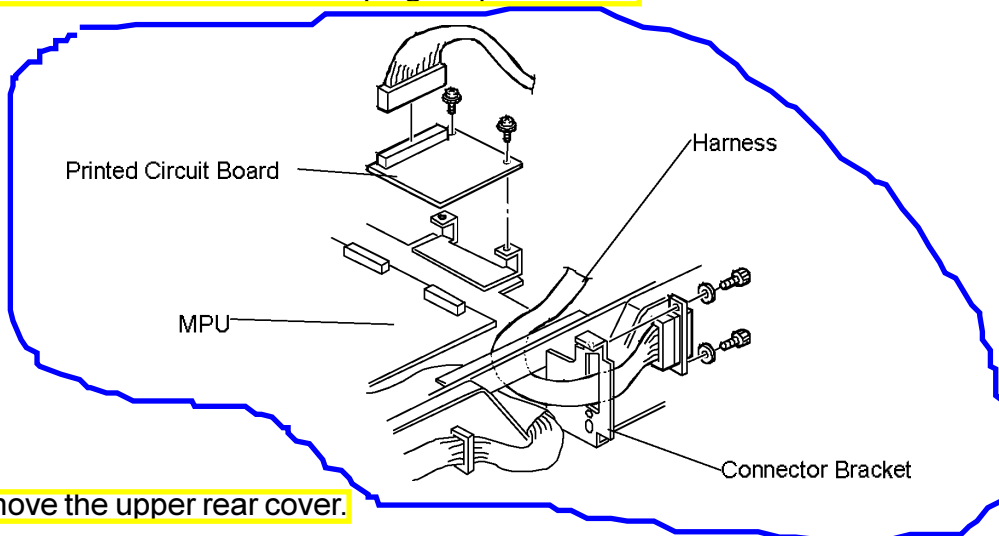

2. Remove the upper rear cover.
3. Remove the MPU cover.
4. Connect CN102 of the printed circuit board (32) to CN110 of the MPU board and secure it using two screws (35).
5. Connect the harness (33) to CN101 of the printed circuit Board, and secure it to the connector bracket using two stepped screws (34).
6. Remove the communications port cover plate (blinding cover) from the upper rear cover.
7. Reinstall the MPU cover.
8. Reinstall the upper rear cover.

- NOTE:** The On-line key on the operation panel is enabled automatically when the UC5E and interface kit are installed.

6. DISASSEMBLY / ASSEMBLY

6.1 REQUIRED TOOLS AND PRECAUTIONS

- Anti-static wrist strap.
- #1 Phillips screwdriver.
- 1 Flathead screwdriver

DANGER

The UC5E's power supply becomes hazardous with the chassis opened. It exposes you to severe electrical shock if you do not disconnect the power cord before opening.

CAUTION

The electronic components in this unit can be damaged by static discharge. Please ensure that you are properly grounded before touching any portion of the electronics. Also, touch the chassis with your finger before connecting test cables, setting switches or reattaching components.



6.2 ZIPRIP FOR MODEL C237

(Refer to page 5 for the Driver Groups)

Tools required:-



- a. Phillips screw driver
- b. Flat head screw driver
- c. Antistatic equipment

Discard the following parts for this installation:-

- a. Part No. VU5E05301
- b. Part No. VU5E05404
- c. Part No. VU5E05402
- d. Part No. VU5E10002

Installation Time:-

This installation should take 30 minutes excluding the time taken to install the video board.

1. Turn off the main switch and unplug the power cord.
2. Remove your UC5E and ancillary items from the box.
3. Open the scanner unit.
4. Remove the upper rear cover.
5. Remove the rear cover.
6. Remove the MPU cover.

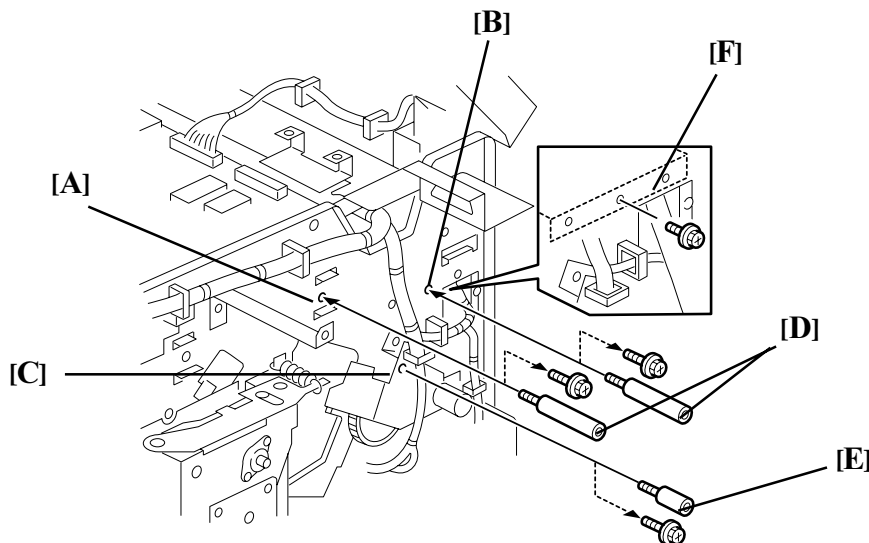

Figure 2a.

7. Remove screws [A], [B] and [C]. Keep them aside for later use.
8. Locate the three standoffs supplied. Mount them into the holes as follows:
Into hole marked [A] in Figure 2a screw in the 45mm standoff [D].
Into hole marked [B] in Figure 2a screw in the 45mm standoff [D].
Into hole marked [C] in Figure 2a screw in the 26mm standoff [E].

NOTE:

- 1) Tighten these standoffs with a flat screwdriver.
- 2) The bracket [F] becomes free without screw [B] Hold bracket [F] by the hand until you screw in standoff [D].

6.3 ZIPRIP FOR MODEL C235

(Refer to page 5 for the Driver Groups)

Tools required:-

- a. Phillips screw driver
- b. Flat head screw driver
- c. Antistatic equipment

Discard the following parts for this installation:-

- a. Part No. VU5E06300
- b. Part No. VU5E05403
- c. Part No. VU5E05405
- d. Part No. VU5E10001
- e. Part No. VU5E05401

Installation Time:-

This installation should take 30 minutes excluding the time taken to install the video board.

1. Turn off the main switch and unplug the power cord.
2. Remove your UC5E and ancillary items from the box.
3. Remove the rear cover.

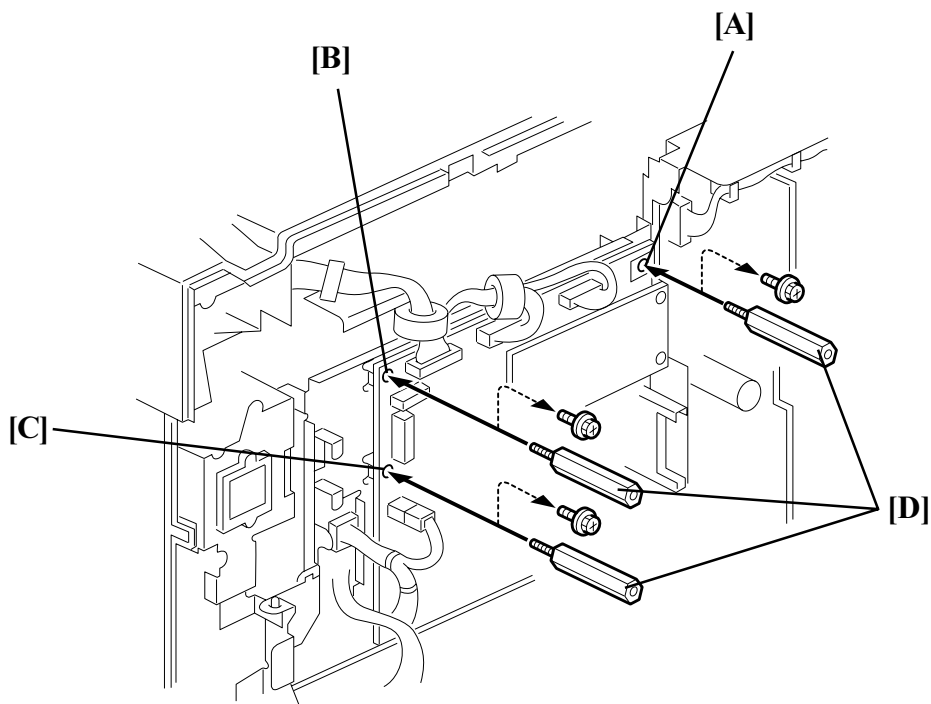

Figure 3a.

4. Remove screws [A], [B] and [C]. Keep them aside for later use.
5. Locate the three M3 x 35mm standoffs [D] supplied. Mount them into the holes.

NOTE:

Care must be taken not to damage the Digital Duplicator MPU

7.3. PC CONTROLLER I/F KIT TYPE-10

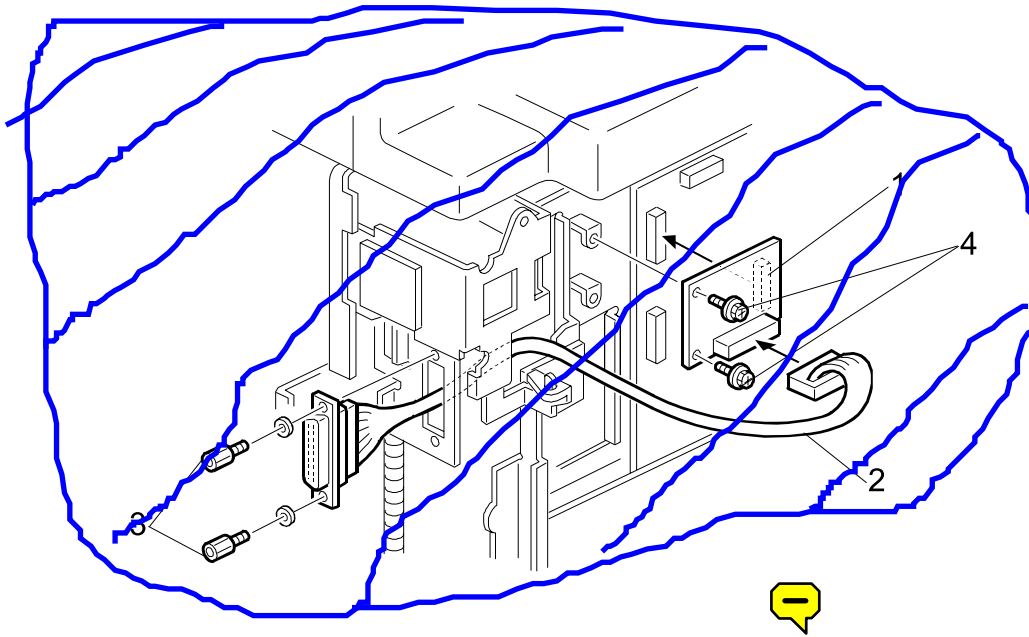

Model C237

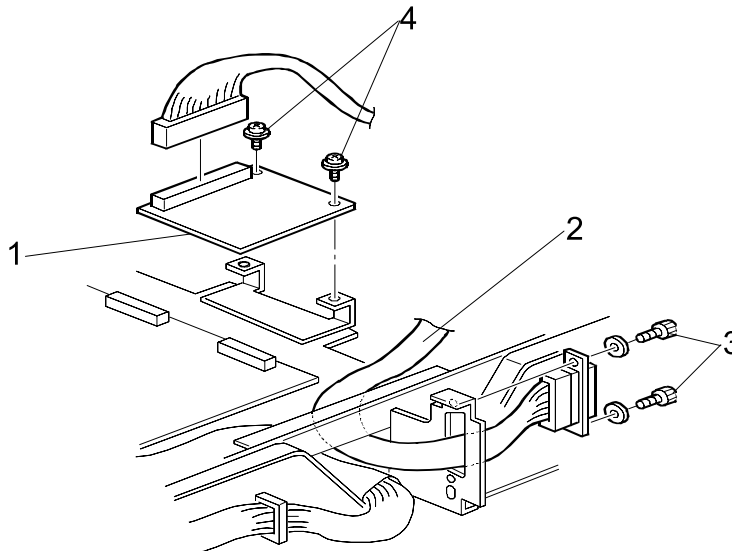

Index No.	Part No.	Description	Q'ty Per Assembly
1	C580 1011	Interface Board	1
2	C580 1500	Relay Harness	1
3	C580 1550	Stepped Screw – M2.6	2
4	0451 3006B	Tapping Screw – M3 x 6	2